

TWIN FLAT

na torze RAMA
lower track RAMA

40
kg



Rama



PŁYTA | BOARD

10 mm



LUSTRO / MIRROR

4,6 mm

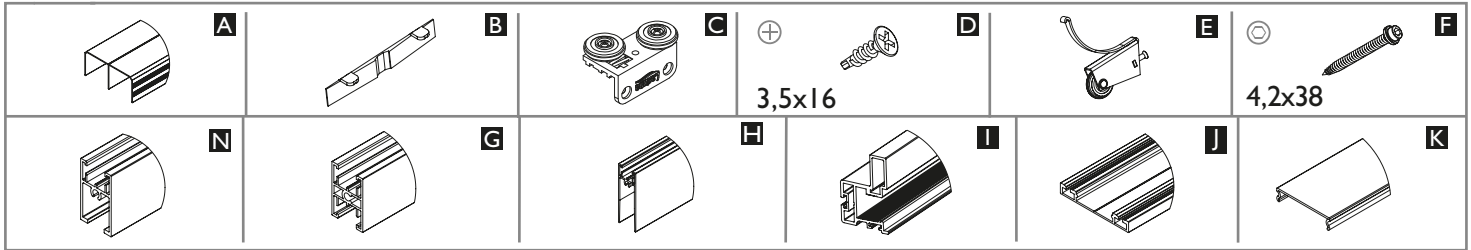
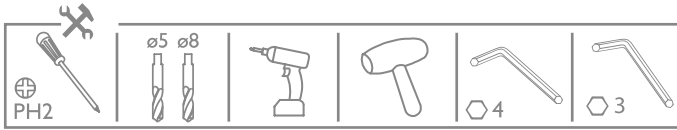

		Liczba skrzydeł n / Quantity of doors n						
		n = 2	n = 3	n = 4	n = 5	n = 6	n = 7	n = 8
8, 10 mm PŁYTA BOARD	Wysokość płyty hP [mm] / Board height hP [mm]	hP = H-104						
	Szerokość płyty bP [mm] / Board width bP [mm]	$bP = (S-4)/2$	$bP = (S+7)/3$	$bP = (S+18)/4$	$bP = (S+30)/5$	$bP = (S+41)/6$	$bP = (S+53)/7$	$bP = (S+64)/8$
	Długość ramiaka dolnego, górnego oraz łącznika R [mm] Upper, lower rail and connector length R [mm]	R = bP-20						
	Długość rączki LR [mm] / Handle length LR [mm]	LR = H-40						
4,6 mm LUSTRO / MIRROR	Wysokość lustra hL [mm] / Mirror height hL [mm]	hL = H-107						
	Szerokość lustra bL [mm] / Mirror width bL [mm]	$bL = (S-10)/2$	$bL = (S-2)/3$	$bL = (S+6)/4$	$bL = (S+15)/5$	$bL = (S+23)/6$	$bL = (S+32)/7$	$bL = (S+40)/8$
	Długość ramiaka dolnego, górnego oraz łącznika R [mm] Długość ramiaka dolnego, górnego oraz łącznika R [mm]	R = bL-17						
	Długość rączki LR [mm] / Handle length LR [mm]	LR = H-40						

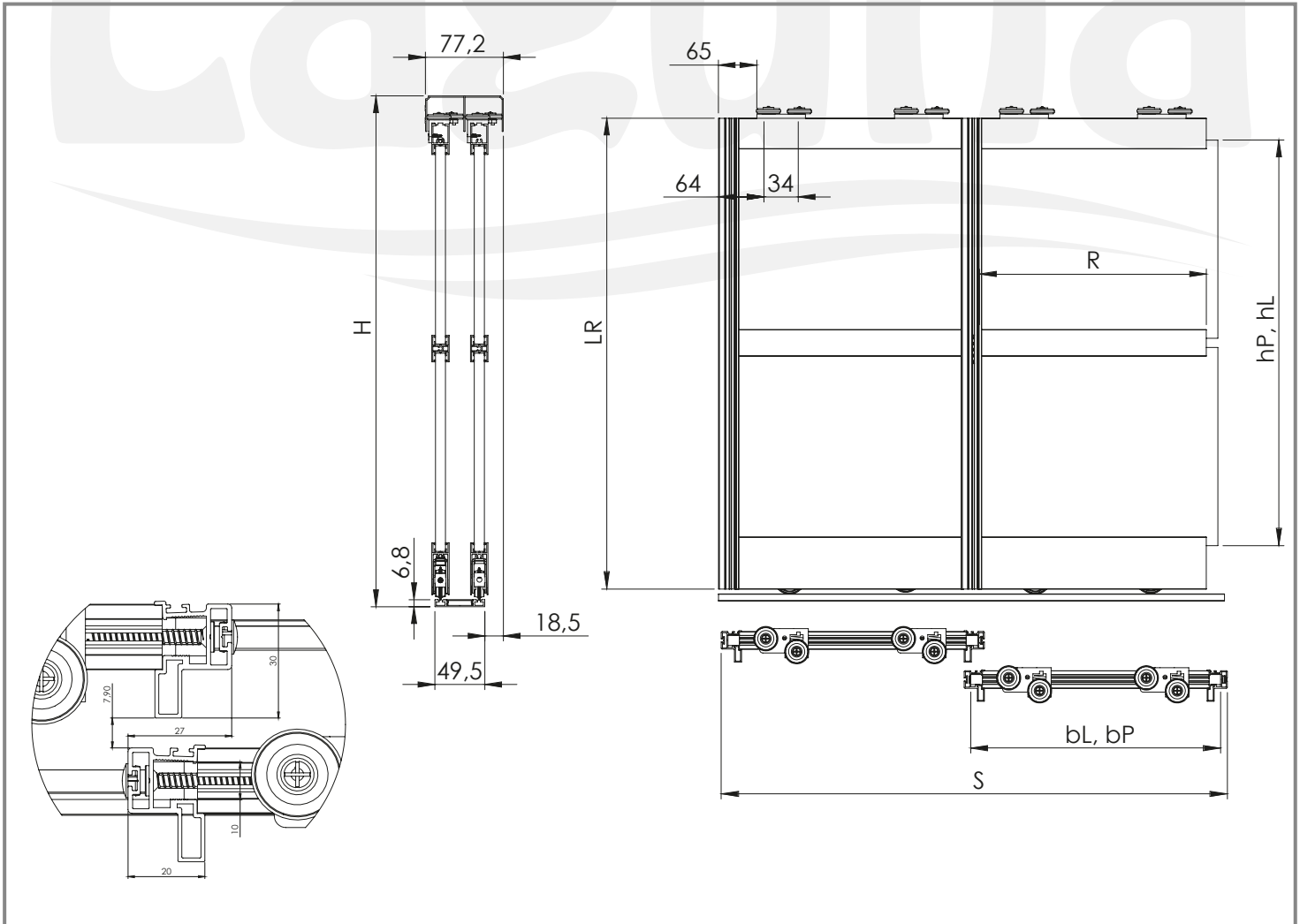

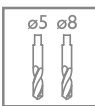

A, B, I, O

1

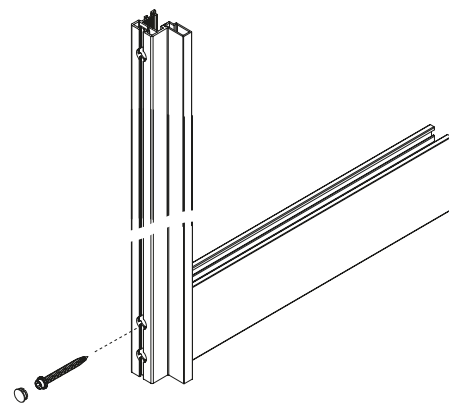
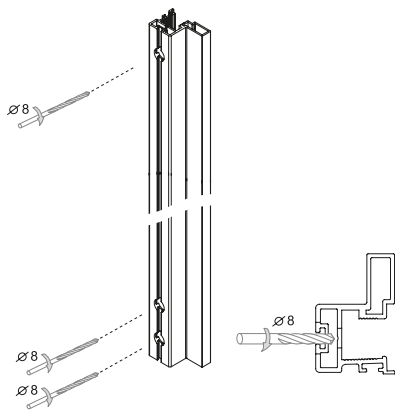
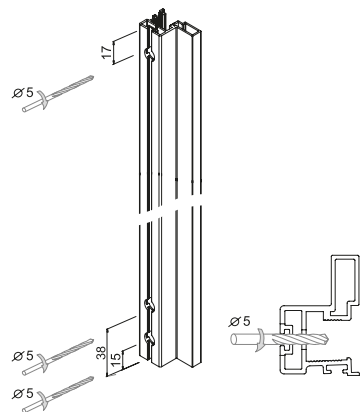

2.1

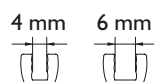
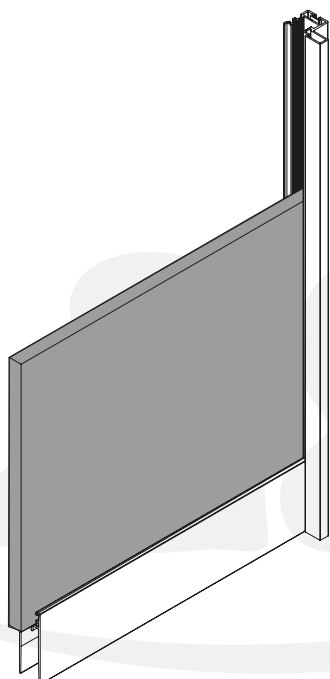
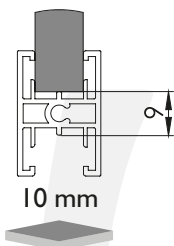

2.2

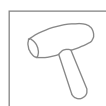
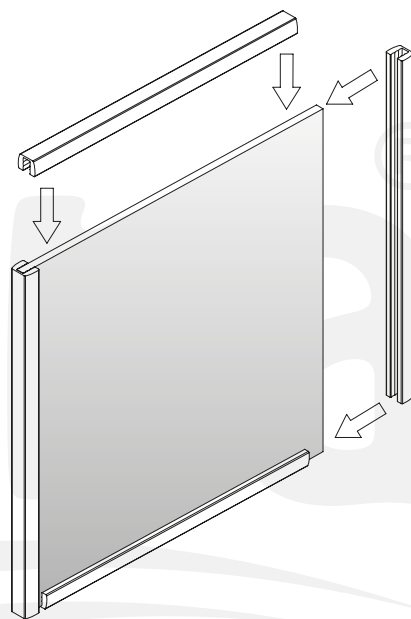
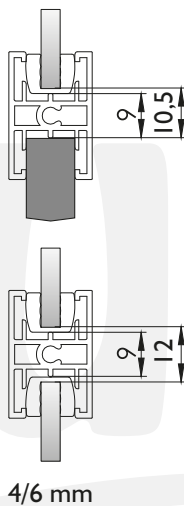

3

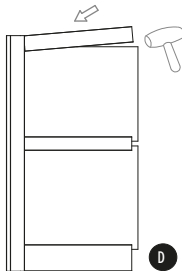
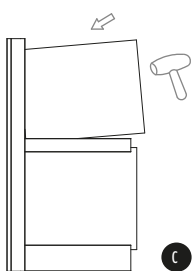
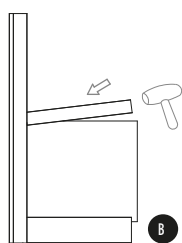
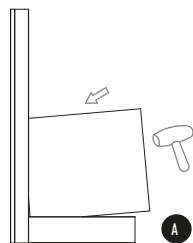

I, F

4

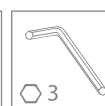
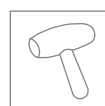
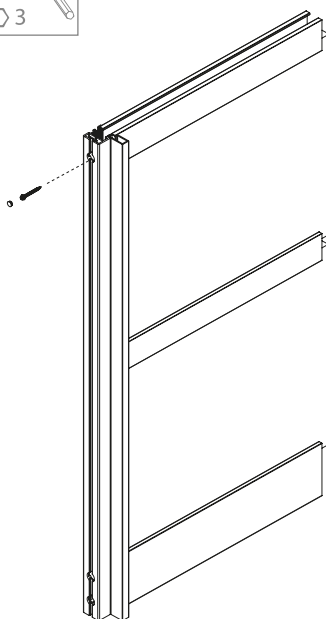

I, F

5

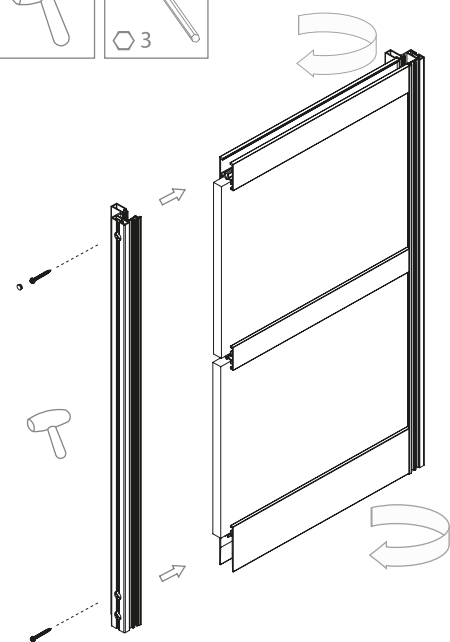



C, E, D

6

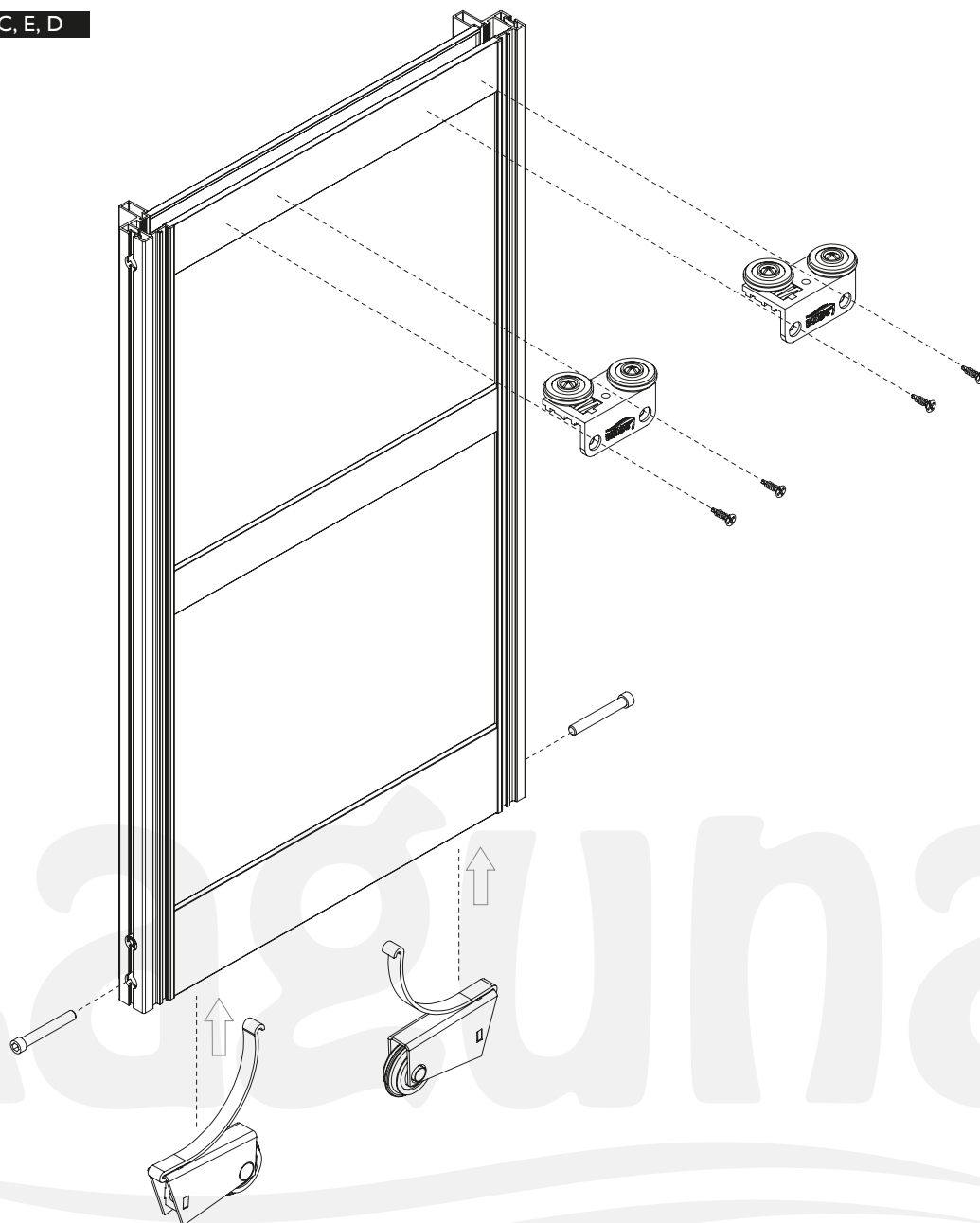

7



J, K

8

Front zabudowy

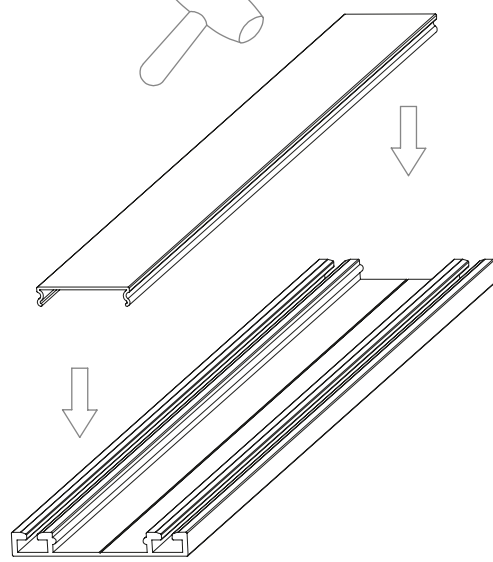
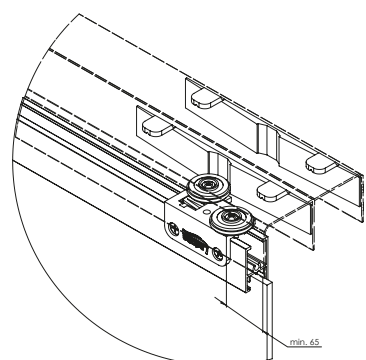
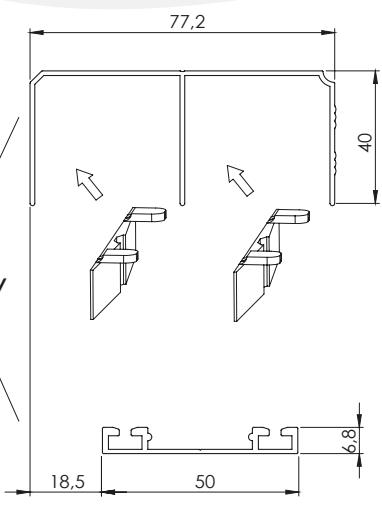

9

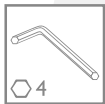
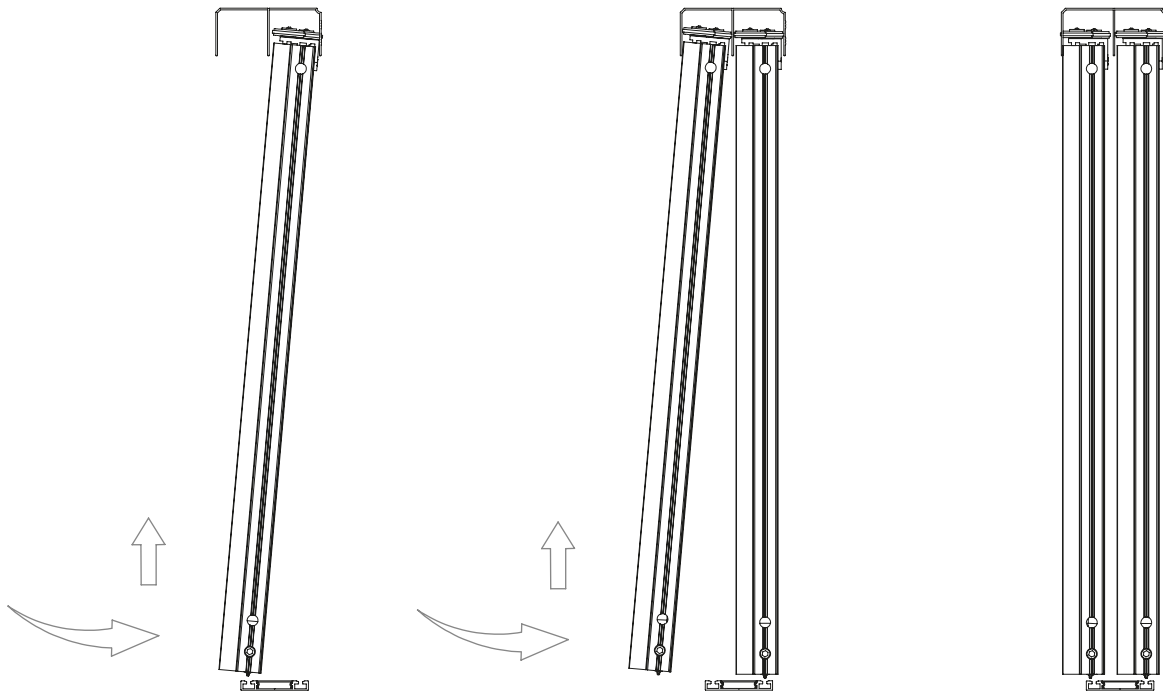

10

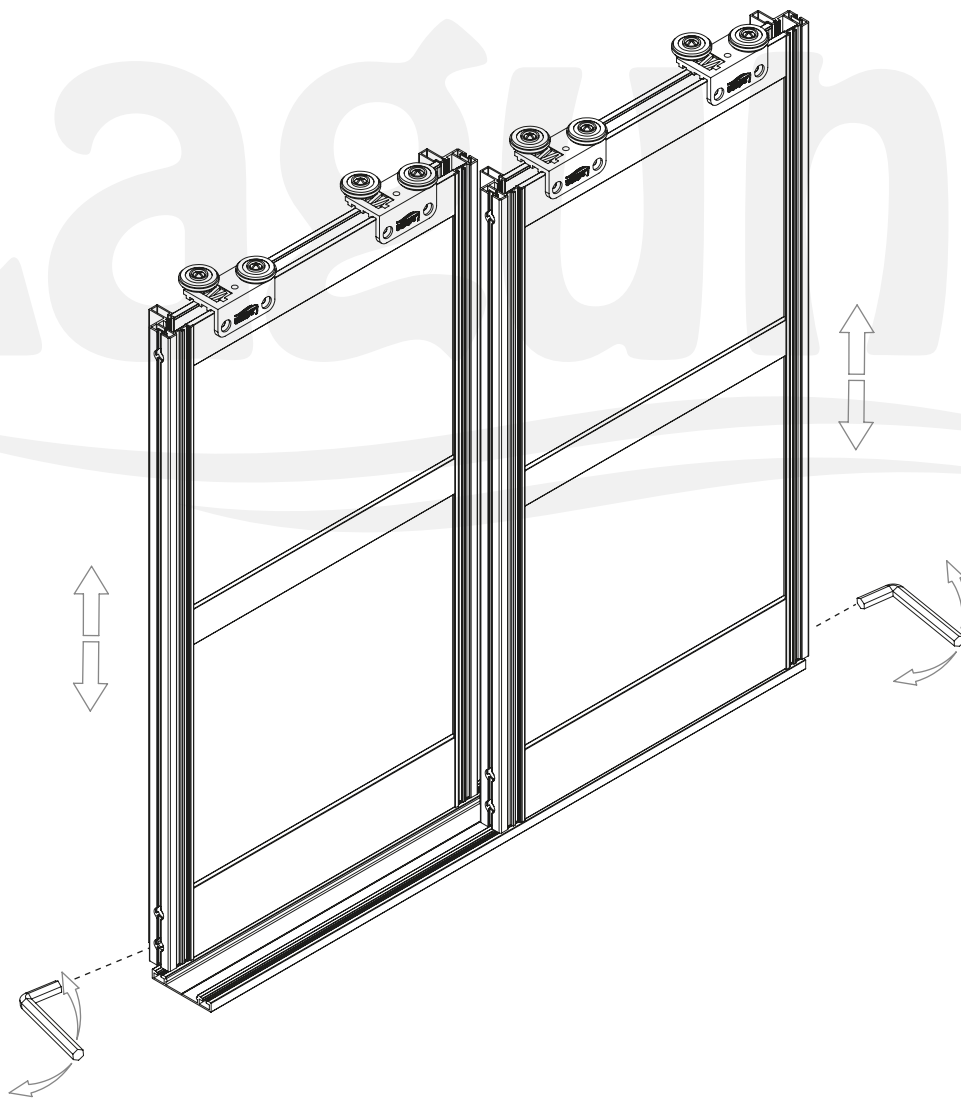

Zaleca się postępowanie zgodnie z niniejszą instrukcją przy użyciu odpowiednich narzędzi, zgodnych ze wskazaniami. W przypadku elementów, których powierzchnia może być ostra należy stosować środki ochrony indywidualnej oraz zabezpieczenie obszaru pracy. Firma Laguna Fabryka Okuć Sp. z o.o. Sp. k. uchyla się od odpowiedzialności za działania wynikające z postępowania niezgodnego z niniejszą instrukcją.

It is recommended that you follow these instructions using the appropriate tools as indicated. In the case of elements whose surface can be sharp, use personal protective equipment and work area protection. The company Laguna Hardware Factory Limited Liability Limited Partnership refrains from liability for actions resulting from conduct incompatible with this instruction.